



FRONT RANGE FIRE RESCUE

PO Box 130, Milliken, CO 80543

970-587-4464 / Fax: 970-587-0324

Courage ★ Compassion ★ Professionalism

Serving Johnstown, Milliken and Weld County for more than 100 years

AMENDMENTS TO 2018 INTERNATIONAL FIRE CODE

The International Fire Code 2018 edition, including all chapters and appendices, is hereby adopted with the following amendments:

Chapter 1 – Administration

Section 101.1 is hereby amended to read as follows:

101.1 Title. These regulations shall be known as the Fire Code of the Town of Milliken, hereinafter referred to as “this code.”

Section 105.6.15 Fire hydrants and valves is hereby deleted in its entirety.

Section 105.6.17 Floor finishing is hereby deleted in its entirety.

Section 105.6.29 Miscellaneous combustibile storage is hereby deleted in its entirety.

Section 105.6.39 Private fire hydrants is hereby deleted in its entirety.

Section 105.6.42 Refrigeration equipment is hereby deleted in its entirety.

Section 105.6.50 Wood products is hereby deleted in its entirety.

Section 105.6.16 Flammable and combustibile liquids. The following portions of this subsection are hereby amended as follows:

2. To store, handle or use Class I liquids in excess of 10 gallons in a building or in excess of 50 gallons outside of a building, except that a permit is not required for the following:

3. To store, handle or use Class II or Class IIIA liquids in excess of 50 gallons in a building or in excess of 499 gallons outside a building, except for fuel oil used in connection with oil-burning equipment.

Section 105.6.30 Mobile food preparation vehicles. This subsection is hereby amended to read as follows:

105.6.30 Mobile food preparation vehicles. A permit is required for mobile food preparation vehicles equipped with appliances that produce smoke or grease-laden vapors. Businesses shall be required to comply with Annex B of NFPA 96 (2017):

Standard of Ventilation Control and Fire Protection of Commercial Cooking Operations, as well as specific policies adopted by the District.

Section 105.6.36 is hereby amended to read as follows:

105.6.36 Outdoor assembly event. An operational permit is required to conduct an outdoor assembly event where planned attendance exceeds 1000 persons or where the event includes *high-risk activities* as defined in Chapter 2 of this code.

Section 105.6.47 Temporary membrane structures and tents is hereby amended to read as follows:

105.6.43 Temporary membrane structures and tents. An operational permit is required to operate an air-supported temporary membrane structure or a tent having an area in excess of 700 square feet.

Section 105.6.51 Marijuana and/or hemp establishments or businesses is hereby created to read as follows:

105.6.51 Marijuana and/or hemp establishments or businesses. Businesses or establishments that sell, grow, or process marijuana or hemp, or businesses or establishments that perform extractions of marijuana or hemp, shall be required to comply with Chapter 38 of NFPA 1: Fire Code, as well as specific policies adopted by the District, to include obtaining the required permit(s) for the operations of said business or establishment.

Section 109.1 is hereby amended to read as follows:

109.1 Board of appeals established. In order to hear and decide appeals of orders, decisions or determinations made by the *fire code official* relative to the application and interpretation of this code, there shall be and is hereby created a board of appeals. The board of appeals shall be appointed by the Town of Milliken governing body, shall hold office at its pleasure, and shall be comprised of the members of the Board of Adjustments. The board shall adopt rules of procedure for conducting its business, and shall render all decisions and findings in writing to the appellant with a duplicate copy to the *fire code official*.

Section 110.1 Unlawful acts. This subsection is hereby amended by the addition of the following:

110.1.1 Unlawful parking. Vehicles parked in fire apparatus access roads marked in accordance with Appendix D, Section 103.6 shall be in violation of the municipal code and model traffic code of the municipality where located.

Section 110.4 Violation penalties is hereby amended to read as follows:

110.4 Violation penalties. Persons who shall violate any provision of this code or shall fail to comply with any of the requirements thereof or who shall erect, install, alter, repair or do work in violation of the approved construction documents or directive of the fire code official, or of a permit or certificate used under provisions of this code, shall be charged with a misdemeanor, and upon conviction shall be subject to the penalties, costs and orders as provided by the municipal court system. Each day that a violation continues after due notice has been served shall be deemed a separate offense.

Section 112.4 is hereby amended to read as follows:

112.4 Failure to comply. Any person who shall continue any work after having been served with a stop work order subject to the adopting of the 2018 IFC, except such work as that person is directed to perform to remove a violation or unsafe condition, shall be liable to a fine of \$500.

Section 114 is hereby created and reads as follows:

Section 114 Reporting of Emergencies and False Alarms.

114.1 General. Reporting of fires and hazardous materials releases shall be in accordance with Section 114.

114.2 Reporting emergencies. In the event a fire occurs or the discovery of a fire, smoke or unauthorized release of flammable, combustible or hazardous materials on any property damage occurs, the owner, owner's authorized representative or occupant shall without delay report such condition to the fire department.

114.3 False alarms. False alarms shall not be given, signaled or transmitted or caused or permitted to be given, signaled or transmitted in any manner.

Chapter 2 – Definitions

Section 202 General Definitions is hereby amended by the following additions:

BOARD. Where the term "Board" is used, it shall be held to mean the Board of Directors of the Front Range Fire Rescue Fire Protection District.

BOARD OF APPEALS. Where the term "Board of Appeals" is used, it shall refer to the District's Board of Appeals, as established, or to the board of appeals established by the applicable municipality or county, if any.

DISTRICT. Wherever the word "District" is used, it shall be held to mean the Front Range Fire Rescue Fire Protection District.

HIGH-RISK ACTIVITIES. Special events shall be deemed to be “high-risk activities” if they include the following proposed activities: display of fireworks, high-speed operation of motor vehicles, mobile food vendors, parades, races, temporary road closures, inflatable attractions, or public alcohol sales and/or consumption.

JURISDICTION. Wherever the word "Jurisdiction" is used it shall be held to mean to the inclusive boundaries of the fire protection district.

RURAL FIRE FLOW AREA. The geographic area as determined by the fire code official that traditionally has had limited fire flow.

URBAN FIRE FLOW AREA. The geographic area as determined by the fire code official that traditionally has had adequate fire flow.

Chapter 3 – General Requirements

Section 307.1.1 is hereby amended to read as follows:

307.1.1 Prohibited open burning. Open burning shall be prohibited when atmospheric conditions or local circumstances make such fire hazardous. Open burning shall be specifically prohibited during active Red Flag Warnings.

Exceptions:

1. Prescribed burning for the purpose of reducing the impact of wildland fire when authorized by the *fire code official*.
2. Agricultural burning that is approved by the *fire code official* and is conducted in accordance with Colorado Air Quality Control Commission Regulation Number 9 (5 CCR 1001-11).

Section 307.2 is hereby amended to read as follows:

307.2 Permit required. A permit shall be obtained from the County health department of jurisdiction in accordance with Section 105.6.32 prior to kindling a fire for recognized silvicultural or range or wildlife management practices, or prevention or control of disease or pests. Application for such approval shall only be presented by and permits issued to the owner of the land on which the fire is to be kindled.

Section 308.1.6.3 is hereby amended to read as follows:

308.1.6.3 Sky lanterns. The use, lighting, tethering or release of sky lanterns is prohibited.

Section 311.5 is hereby amended to read as follows:

311.5 Placards. The *fire code* official is authorized to require any vacant or abandoned buildings or structures determined to be unsafe pursuant to Section 110 of this code relating to structural or interior hazards to be marked as required by Sections 311.5.1 through 311.5.5.

Chapter 5 – Fire Service Features

Section 503.1 is hereby amended to read as follows:

503.1 Where required. Fire apparatus access roads shall be provided and maintained in accordance with Section 503.1 through 503.6 and Appendix D “Fire Apparatus Access Roads.”

Section 503.1.1 Exception 1.1 is hereby amended to read as follows:

Exception 1.1 If the building is equipped throughout with an approved automatic sprinkler system installed in accordance with 903.3.1.1, 903.3.1.2 or 903.3.1.3, the dimension is allowed to increase to 300 feet.

Section 503.1.2 is hereby amended to read as follows:

503.1.2 Additional access. A minimum of two approved fire apparatus access roads shall be provided to each new residential development or new commercial or multi-family building within the jurisdiction. If multiple fire apparatus access roadways cannot be provided, all occupiable structures that are located more than 660 feet from the last roadway providing access from two directions, as measured from the centerline of this last roadway, shall be protected with an approved automatic fire sprinkler system.

Exception: Where all occupiable structures beyond 660 feet (201 m) of the centerline of the last roadway providing access to the dead-end road are equipped throughout with an approved automatic sprinkler system in accordance with Section 903.3.1.1, 903.3.1.2 or 903.3.1.3.3, access from two directions shall not be required.

Section 503.1.2.1 is hereby created and reads as follows:

503.1.2.1 Access to buildings. A minimum of two approved fire apparatus access drives shall be provided to each building or portion of building hereafter constructed or moved into the jurisdiction.

Exception: One- and two-family dwellings.

Section 503.1.3 is hereby created and reads as follows:

503.1.3 Limited access. The fire code official is authorized to modify the fire apparatus access requirements due to existing waterways, topography, hazards or other factors.

Section 503.2 is hereby amended to read as follows:

503.2 Specifications. Fire apparatus access roads shall be installed and arranged in accordance with Sections 503.2.1 through 503.2.8, and Appendix D of this code.

Section 503.2.7 is hereby amended to read as follows:

503.2.7. Grade. Fire apparatus access roads shall not exceed 10 percent in grade.

Exception: Grades steeper than 10 percent as approved by the fire code official.

Section 503.2.8 is hereby amended to read as follows:

503.2.8 Angles of approach and departure. Grade changes upon a fire apparatus access road or when entering or exiting from or to a fire apparatus access road, shall not exceed a 10 percent angle of approach or angle of departure.

Section 505.1 is hereby amended to read as follows:

Section 505.1 Address identification. New and existing buildings or facilities shall be provided with *approved* address identification. The address identification shall be legible and placed in a position that is visible from the street or road fronting the property. Address identification characters shall contrast with their background. Address numerals shall be Arabic numbers and street names, if required to be installed with the numerals, shall be alphabet letters. Numbers shall not be spelled out with alphabet letters. Address identification shall be maintained.

505.1.1 Addresses shall be assigned by the governmental entity having jurisdiction and shall comply with the Town of Milliken Addressing System as well as the addressing standards of the county in which the property is located. At no time shall any new street be assigned the same name as, or one substantially similar to, any existing street name in the fire district providing primary emergency response.

505.1.2 The approved address numerals shall be visible from the street fronting the property, and posted on a contrasting background. Bronze or brass numerals shall not be posted on a brick background.

- 505.1.3** The address numerals for any commercial or industrial buildings shall be placed at a height to be clearly visible from the street. Where required by the fire code official, address identification shall be provided in additional, approved locations to facilitate emergency response.
- 505.1.4** Where access is by means of a private road and the building cannot be viewed from the public way, a monument, pole or other sign or means shall be used to identify the structure.
- 505.1.5** Commercial or multiple-family buildings shall have numerals with a minimum height of six inches and stroke width of one-half inch. Buildings three or more stories in height or with a total floor area of 15,000 to 50,000 square feet, shall have numerals with a minimum eight-inch height and stroke width of one inch. Buildings with a total floor area of 50,000 square feet or greater shall have numerals with a minimum height of 12 inches and stroke width of 1.5 inches.
- 505.1.6** Residential buildings that contain no more than two dwelling units shall have a minimum four-inch high numerals, with a minimum stroke width of one-half inch.
- 505.1.7** Individual suite or unit addresses shall be displayed with minimum four-inch high numerals, with a minimum stroke width of one-half inch.
- 505.1.8** Monument signs shall not be used in lieu of address numerals on the building.
- 505.1.9** Buildings with multiple suites, apartments or units shall have the individual suites, apartments or units provided with individual identification numbers in an approved, sequential order. Suites, apartments or units located on the first floor shall be identified by numbers within the 100 or 1000 range or series; Suites, apartments or units located on the second floor shall be identified by numbers within the 200 or 2000 range or series; Suites, apartments or units located on the third floor units shall be identified by numbers within the 300 or 3000 range or series. Higher floors shall follow this same numbering scheme. Floors below grade shall be identified with numerals within the 0100 range on the first floor below grade and 0200 on the second floor below grade; lower floors shall follow the same numbering pattern.
- 505.1.10** Buildings, either individually or part of a multi-building complex, that have emergency access lanes on sides other than on the addressed street side, may be required to have the address numerals and street name on each side that fronts the fire lane(s).

505.1.11 Buildings that are addressed on one street, but are accessible from an adjoining street, may be required to affix the address numerals and street name on each side that is adjacent to the other street(s).

505.1.12 Approved signage shall be provided in conspicuous locations on or within buildings to provide clear direction to locate any suite, apartment or unit within the building.

505.1.13 Multiple-building complexes shall be provided with approved signage as needed to direct first responders to individual buildings.

Section 507.3 Fire flow is hereby amended to read as follows:

507.3 Fire flow. Fire flow requirements for buildings or portions of buildings and facilities shall be determined in accordance with Appendix B of this code.

Section 507.5.1.1 is hereby amended to read as follows:

507.5.1.1 Hydrant for fire department connections. Buildings equipped with a fire department connection shall have a fire hydrant located with 150 feet of the fire department connection, using an approved route without obstacles. The hydrant and fire department connection shall be on the same side of the fire apparatus access road or parking lot drive aisle, unless otherwise approved by the fire code official.

Exception: The distance shall be permitted to exceed 150 feet where approved by the fire code official.

Section 509.1.2 is hereby created and reads as follows:

509.1.2 Utility disconnect. The fire code official is authorized to approve utility disconnect locations.

Chapter 9 – Fire Protection Systems

Section 901.1 is hereby amended to read as follows:

901.1. Scope. The provisions of this chapter shall specify where fire protection and life safety systems are required and shall apply to the design, installation, inspection, operation, testing and maintenance of all fire protection systems. Where requirements of this code and the International Building Code are in conflict, the more restrictive shall apply.

Section 903.2.8.4.5 is hereby created and reads as follows:

903.2.8.4.5. Dead-end roadways. An approved automatic fire-sprinkler system shall be installed in all Group R occupancies, including one- and two-family residences and townhomes, when the structure is located beyond 660 feet of the

entrance to a dead-end roadway, as measured from the centerline of the last roadway providing access to the dead-end road.

Section 903.2.9 is amended with the addition of **Condition #6** which reads as follows:

6. A Group S-1 fire area exceeds 5,000 square feet (464.5 m²) for self-storage buildings or structures.

Section 903.4.3 is hereby amended to read as follows:

903.4.3 Control Valves. Approved supervised indicating control valves shall be provided at the point of connection to the riser on each floor in all multi-story structures and to each individual tenant space in multi-tenant structures.

Section 907.5.2 is hereby amended to read as follows:

907.5.2 Alarm notification appliances. Alarm notification appliances shall provide full occupant notification throughout the entire building or structure, and shall be designed and installed in accordance with NFPA 72. Alarm notification appliances shall be listed for their purpose.

Chapter 31 – Tents, Temporary Special Event Structures and Other Membrane Structures

Section 3103.2 is hereby amended to read as follows; however, the exceptions remain unchanged:

3103.2 Approval Required. Tents, canopies and membrane structures ~~having an area~~ in excess of 700 square feet in size shall not be erected, operated or maintained for any purpose without first obtaining a permit and approval from the fire code official.

Section 3106.4.1.1 Standby emergency medical services is hereby created to read as follows:

3106.4.1.1 Standby emergency medical services. Public assembly events with an anticipated attendance of 350 persons or more shall require the standby services of at least one (1) basic life support ambulance staffed with at least two (2) EMT-Basics. Public assembly events with an anticipated attendance of more than 1,000 persons shall require the standby services of at least one (1) advanced life support ambulance staffed with at least one (1) EMT-Paramedic and one (1) EMT-Basic. The fire code official is authorized to grant exceptions and/or alternate plans for the provision of standby emergency medical services.

Chapter 50 – Hazardous Materials – General Provisions

Section 5001.1 Scope Exception #10 is hereby amended to read as follows:

10. The production, processing and/or storage of distilled spirits and wines in wooden barrels and casks when the building or facility is conformance with “Recommended Fire Protection Practices for Distilled Spirits Beverage Facilities” as published by the Distilled Spirits Council of the United States (DISCUS).

Chapter 56 – Explosives and Fireworks

Section 5601.1.3 Fireworks is hereby amended to read as follows:

5601.1.3 Fireworks. The possession, manufacture, storage, sale, handling and use of fireworks are prohibited unless permitted by state or local laws.

Section 5601.1.3, Exception 4 is hereby amended as follows:

4. The possession, storage, sale, handling and use of Permissible Fireworks in accordance with state statute and local municipal codes.

Section 5601.2.2 is hereby amended to read as follows:

5601.2.2 Sale and retail display. Persons shall not construct a retail display nor offer for sale explosives, explosive materials or fireworks on highways, sidewalks, public property or in any permanent building.

Section 5602 Definitions is hereby amended with the addition of the following definition:

Permissible Fireworks. As defined in Colorado Revised Statutes, 12-28-101 § CRS.

Section 5610 Permissible fireworks is hereby created to read as follows:

5610 Permissible fireworks. Permissible fireworks shall be possessed, stored, sold, handled and used in accordance with this section and with state and local laws.

5610.1 General. Permissible fireworks use shall be as detailed in this section and in accordance with state and local laws.

5610.2 Use of fireworks. The use of permissible fireworks shall be in accordance with Sections 5610.2.1 through 5610.2.4.

5610.2.1 It shall be unlawful for any person to possess, store, offer for sale, expose for sale, sell at retail, use, or discharge any fireworks, other than permissible fireworks.

5610.2.2 It shall be unlawful for any person to knowingly furnish to any person under 16 years of age, by gift, sale, or any other means, any fireworks, including permissible fireworks.

5610.2.3 It shall be unlawful for any person under 16 years of age to purchase fireworks, including permissible fireworks.

5610.2.4 It shall not be unlawful for a person under 16 years of age to possess and discharge permissible fireworks if such person is under adult supervision throughout the act of possession and discharge.

Chapter 57 – Flammable and Combustible Liquids

Section 5701.2 Non-applicability Exception #10 is hereby amended to read as follows:

10. The production, processing and/or storage of distilled spirits and wines in wooden barrels and casks when the building or facility is conformance with “Recommended Fire Protection Practices for Distilled Spirits Beverage Facilities” as published by the Distilled Spirits Council of the United States (DISCUS).

Section 5704.2.9.6.1 Locations where above-ground tanks are prohibited is hereby amended to read as follows:

5704.2.9.6.1 Locations where above-ground tanks are prohibited. Storage of Class I and Class II liquids in above-ground tanks outside of buildings is prohibited within the limits established by law as addressed by ordinance and/or zoning regulation adopted by the local government with jurisdiction.

Section 5704.2.14.1 Removal is hereby amended by the following addition:

7. Removal of above-ground and underground tanks shall be in accordance with federal, state and local regulations.

Section 5704.3.3 Indoor storage. Exception #2 is hereby amended to read as follows:

2. The production, processing and/or storage of distilled spirits and wines in wooden barrels and casks when the building or facility is conformance with “Recommended Fire Protection Practices for Distilled Spirits Beverage Facilities” as published by the Distilled Spirits Council of the United States (DISCUS).

Section 5706.2.4.4 Locations where above-ground tanks are prohibited is hereby amended to read as follows:

5706.2.4.4 Locations where above-ground tanks are prohibited. Storage of Class I and Class II liquids in above-ground tanks is prohibited within the limits

established by law as addressed by ordinance and/or zoning regulation adopted by the local government with jurisdiction.

Section 5706.2.4 is hereby amended to read as follows, and the exception is deleted:

5706.2.4. Permanent and temporary tanks. The capacity of permanent above-ground tanks containing Class I or Class II liquids shall not exceed 500 gallons, and the capacity of temporary above-ground tanks containing Class I or Class II liquids shall not exceed 2,000 gallons, unless larger amounts are approved in writing by the fire code official. Tanks shall be of single-compartment design.

Section 5706.3 Well drilling and operating is hereby amended with the following additions:

5706.3.9 Portable fire extinguishers. Portable fire extinguishers shall be located throughout the site in locations approved by the fire code official.

5706.3.10 Identification of hazards. All hazardous materials tanks or containers shall be appropriately labeled in accordance with NFPA 704, or other standard as approved by the fire code official. All hazard markings shall be maintained by the operator.

5706.3.11 Access roads. All access roads to well drilling and operating facilities shall comply with Section 505.1 and Appendix D of this code.

5706.3.12 Facility security. All fences and gates installed to provide facility security shall comply with Section 503.6 of this code. The fire code official may require a Knox Box, Knox Switch, or Knox Padlock to be installed by the operator to provide fire department access to the site.

5706.3.13 Safety regulations. All oil and gas locations shall comply with all Colorado Oil and Gas Conservation Commission (COGCC) rules. COGCC Rule 600 shall be specifically addressed for all site safety requirements.

Chapter 58 – Flammable Gases and Flammable Cryogenic Fluids

Section 5806.2 Limitations is hereby amended to read as follows:

5806.2 Limitations. Storage of flammable cryogenic fluids in stationary containers outside of buildings is prohibited within the limits established by ordinance and/or zoning regulation adopted by the local government with jurisdiction.

Chapter 61 – Liquefied Petroleum Gases

Section 6104.2 Maximum capacity within established limits is hereby amended to read as follows:

6104.2 Maximum capacity within established limits. Within the limits established by law restricting the storage of liquefied petroleum gas for the protection of heavily populated or congested areas, the aggregate capacity of any one installation shall not exceed the limits established by ordinance and/or zoning regulation adopted by the local government with jurisdiction.

Exception: In particular installations, this capacity limit shall be determined by the fire code official, after consideration of special features such as topographical conditions, nature of occupancy, and proximity to buildings, capacity of proposed LP-gas containers, degree of fire protection to be provided and capabilities of the local fire department. These provisions shall not be interpreted so as to conflict with the provisions of Colorado Revised Statutes Title 8, Article 20 or Title 34 as amended. In the event of any conflict, the more restrictive provision shall prevail.

Chapter 80 – Referenced Standards

Chapter 80 Referenced standards is hereby amended with the following additions:

COGCC Colorado Oil and Gas Conservation Commission
1120 Lincoln Street, suite 801
Denver, CO 80203

Rule 600: Safety Regulations

Referenced in Section 5706.3.13

DISCUS Distilled Spirits Council of the United States
1250 Eye Street, NW suite 400
Washington, DC 20005

Recommended Fire Protection Practices for Distilled Spirits Beverage
Facilities, 3rd edition, June 2005

Referenced in Sections 5001.1, 5701.2, 5704.3.3

NFPA National Fire Protection Association
1 Batterymarch Park
Quincy, MA 02169-7471

NFPA 1-18: Fire Code, Chapter 38: Marijuana Growing, Processing, or
Extraction Facilities

Referenced in Subsection 105.6.51

NFPA 96-17: Standard for Ventilation Control and Fire Protection in Commercial Cooking Operations, Annex B

Referenced in Subsection 105.6.30.

Appendices

Only the appendices of the 2018 International Fire Code listed herein are adopted as follows:

APPENDIX B: Fire-Flow Requirements for Buildings is adopted in its entirety, with the following amendment:

Table B105.2, Footnote a. is hereby amended to read as follows:

- a. The reduced fire flow shall be not less than 1,500 gallons per minute

APPENDIX C: Fire Hydrant Locations and Distribution is adopted with the following changes:

Section C101.1 is hereby amended to read as follows:

C101.1 Scope. In addition to the requirements of Section 507.5.1, fire hydrants shall be provided in accordance with this appendix for the protection of buildings, or portions of buildings, hereafter constructed or moved into the jurisdiction. The fire code official is authorized to modify the location, number and distribution of fire hydrants based on site-specific constraints and hazards.

Table C102.1 is hereby amended by renaming it **Table C102.1 Required Number of Fire Hydrants** and deleting columns Average Spacing Between Hydrants and Maximum Distance from any Point on a Street or Road Frontage to a Hydrant, and deleting all footnotes.

Section C103 is hereby amended with the creation of **Table C103.1 Required Spacing of Hydrants** and associated footnotes:

TABLE C103.1

REQUIRED SPACING OF HYDRANTS

APPLICATION	SPACING BETWEEN HYDRANTS (feet) ^{a,b}	MAXIMUM DISTANCE FROM THE CLOSEST POINT ON A BUILDING TO A HYDRANT (feet)
--------------------	---	--

Buildings other than one- and two-family dwellings, Group R-3 and R-4, and townhouses	350	400 ^c
Urban One - and Two-Family Dwellings, Group R-3 and R-4, and townhouses	600	600
Rural One - and Two-Family Dwellings, Group R-3 and R-4, and townhouses	1,000	1,000

- a. Where streets are provided with median dividers that cannot be crossed by fire fighters pulling hose lines, or are arterial streets, hydrant spacing shall average 350 feet on each side of the street and be arranged on an alternating basis.
- b. Where new water mains are extended along streets where hydrants are not needed for protection of structures or similar fire problems, fire hydrants shall be provided at spacing not to exceed 1,000 feet to provide for transportation hazards.
- c. For buildings equipped with a fire department connection, see Section 507.5.1.1.

Section C103.2 is hereby amended to read as follows:

C103.2 Spacing between hydrants. The spacing between fire hydrants shall be in accordance with Table C103.1 (Exception deleted).

Section C103.3 is hereby amended to read as follows:

C103.3 Spacing from hydrants to a building. The maximum spacing from fire hydrants to a structure shall be in accordance with Table C103.1

Section C105 Referenced Standard is hereby deleted in its entirety.

APPENDIX D: Fire Apparatus Access Roads is adopted with the following changes:

Section D102.1 is hereby amended to read as follows:

D102.1 Access and loading. Facilities, buildings or portions of buildings hereafter constructed shall be accessible to fire department apparatus by way of an approved fire apparatus access road capable of supporting the imposed load of fire apparatus weighing at least 80,000 pounds (36,287 kg).

Section D102.2 is hereby created and reads as follows:

D102.2 Roadway surface. All access roadways must be all-weather driving surfaces capable of supporting fire apparatus. Surfaces shall be asphalt or concrete and maintained in a usable condition at all times. Compacted road base or other all-weather surfaces engineered and capable of supporting the imposed loads may be approved for outdoor vehicle storage, ground-mounted solar installations, cell towers and similar isolated facilities and structures when approved by the fire code official.

Section D102.2.1 is hereby created and reads as follows:

D102.2.1 Access during construction. Compacted road base, chip or other all-weather surfaces shall be used only for temporary emergency access. All required access roads must be installed and serviceable before aboveground construction begins. Temporary access shall be available as long as the site is under construction. Thereafter, permanent fire lanes conforming with D102.1 and D102.2 shall be accessible and unobstructed at all times.

Table D103.1 is hereby amended to read as follows:

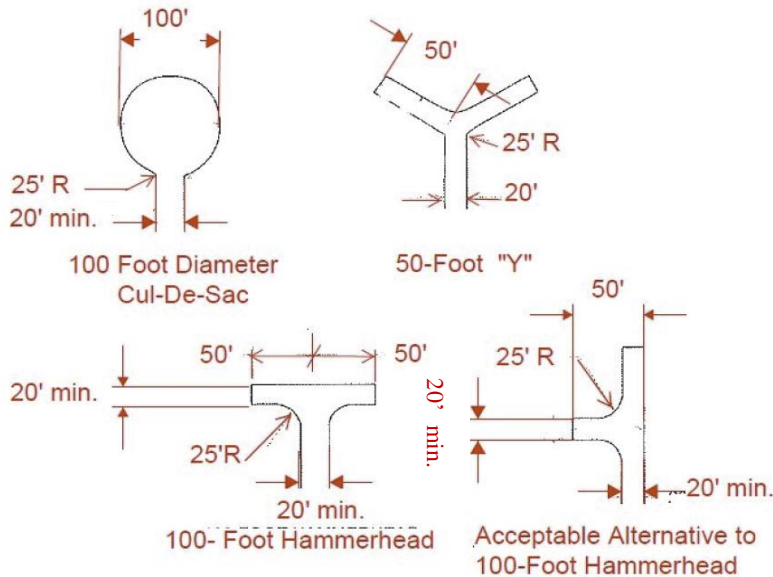

Table D103.4 is hereby amended to read as follows:

**TABLE 103.4
REQUIREMENTS FOR DEAD-END FIRE APPARATUS ACCESS ROADS**

LENGTH (feet)	WIDTH (feet)	TURNAROUNDS REQUIRED
0-150	20	None required
151 and longer	20	100-foot hammerhead, 100-foot cul-de-sac in accordance with Figure D103.1

Section D103.3 is hereby amended to read as follows:

D103.3 Turning radius. The minimum turning radius shall be 25 feet inside radius and 50 feet outside radius.

Section D103.5 is amended with the addition of an exception that reads as follows:

Exception: Private driveways serving one (1) single-family residence.

Section D103.6 is hereby amended to read as follows:

D103.6 Signs. Where required by the fire code official, fire apparatus access roads shall be marked with permanent NO PARKING – FIRE LANE signs complying with Chapter 2B of the Manual on Uniform Traffic Control Devices. Signs shall be posted on one or both sides of the fire apparatus road as required by Section D103.6.1 or D103.6.2.

Figure D103.6 Fire Lane Signs is hereby deleted in its entirety.

Section D104 is hereby amended to read as follows:

Section D104 Emergency Vehicle Access to all Developments

D104.1 Multiple access. A minimum of two approved fire-apparatus access roads shall be provided to each developed lot within the jurisdiction. If multiple fire apparatus access roadways cannot be provided and the single, dead-end roadway is in excess of 660 feet in length, as measured from the centerline of the last roadway providing access to the dead-end road, all occupiable structures located beyond 660 feet shall be protected with an approved automatic fire sprinkler system.

Exception: Where all occupiable structures beyond 660 feet (201 m) of the centerline of the last roadway providing access to the dead-end road are

equipped throughout with an approved automatic sprinkler system in accordance with Section 903.3.1.1, 903.3.1.2 or 903.3.1.3.3, access from two directions shall not be required.

D104.2 Access to buildings. A minimum of two approved fire-apparatus access drives shall be provided to each building or portion of building hereafter constructed or moved into the jurisdiction.

Exception: One- and two-family dwellings.

D104.3 Remoteness. Where two fire apparatus access roads are required, they shall be placed a distance apart equal to not less than one half of the length of the maximum overall diagonal dimension of the lot or area to be served, measured in a straight line between accesses. If all structures are protected by an approved automatic fire-sprinkler system, the access roadways may be placed a distance apart equal to not less than one-third the length of the maximum overall diagonal dimension of the property or area to be served, measured in a straight line.

Section D106 is hereby deleted in its entirety.

Section D107 is hereby deleted in its entirety.

Section D108 is hereby deleted in its entirety.

APPENDIX E: Hazard Categories is adopted in its entirety.

APPENDIX F: Hazard Ranking is adopted in its entirety.

APPENDIX G: Cryogenic Fluids – Weight and Volume Equivalents is adopted in its entirety.

APPENDIX H: Hazardous Materials Management Plan (HMMP) and Hazardous Materials Inventory Statement (HMIS) Instructions is adopted in its entirety.

APPENDIX I: Fire Protection Systems – Noncompliant Conditions is adopted in its entirety.

APPENDIX K: Construction Requirements for Existing Ambulatory Care Facilities is adopted in its entirety.